

MATEUSZ MUSIK\*, JAN TALAGA\*\*

## INVESTIGATION OF FLUID DYNAMICS IN AN UNBAFFLED STIRRED VESSEL WITH AN ECCENTRICALLY LOCATED RUSHTON TURBINE

### BADANIA HYDRODYNAMIKI MIESZANIA W MIESZALNIKU BEZ PRZEGRÓD Z NIECENTRYCZNIE USYTUOWANYM MIESZADŁEM TURBINOWYM

#### Abstract

The paper presents the results of experimental investigation of the hydrodynamics in unbaffled stirred vessel with eccentric Rushton turbine configuration. Basing on flow visualisation, the main flow features were determined. Laser Doppler Anemometry measurements provided radial and axial components of the mean flow velocity vectors. The obtained data of power consumption allowed to determine the impact of the impeller eccentricity ratio  $e/R$  on the power number  $Ne$ .

*Keywords: agitation, eccentrically located impeller, unbaffled vessel, LDA measurements*

#### Streszczenie

W artykule przedstawiono wyniki badań doświadczalnych hydrodynamiki mieszania w zbiorniku bez przegród z niecentrycznie usytuowanym mieszadłem turbinowym tarczowym. Dokonano wizualizacji przepływu. W oparciu o wyniki pomiarów z wykorzystaniem anemometru laserowego wyznaczono rozkłady promieniowej i osiowej składowej średniej prędkości przepływu cieczy. Określono doświadczalnie wpływ niecentryczności  $e/R$  usytuowania mieszadła na liczbę mocy mieszania  $Ne$ .

*Słowa kluczowe: mieszanie, niecentryczne mieszadło, mieszalnik bez przegród, pomiary LDA*

#### DOI:

\* MSc. Eng. Mateusz Musik, Avio Aero GE Aviation business, Turbine Unit Department, Bielsko-Biała, Poland.

\*\* DSc. Eng. Jan Talaga, Institute of Thermal and Process Engineering, Faculty of Mechanical Engineering, Cracow University of Technology.

## 1. Introduction

Mechanical mixing is commonly used in many processes in chemical, food, pharmaceutical or biotechnology industries. A typical design solution of stirred tank is a vertical vessel with a centrally located shaft. Most often, the stirred tank is equipped with four vertical baffles, fixed to the vessel wall, which deter vortex formation and intensify mixing by increasing the axial flow rate [1]. However, in some processes, baffles may cause an undesired effect creating dead zones behind baffles where sludge can accumulate. It can occur especially in stirred tanks with a flat bottom and during multiphase fluid mixing [2]. In such case, it is an alternative solution as unbaffled mixing [3, 4] with eccentrically located impeller. What is more, the design also eliminates unfavourable central vortex formation.

This paper presents an experimental investigation of hydrodynamics and power consumption of mixing in unbaffled stirred tank with eccentrically located Rushton impeller.

## 2. Experimental

Research was performed in a vertical tank (Fig. 1a) made of *Duran* glass with inside diameter  $D = 0,286$  m and flat bottom. Liquid level were equal to tank inside diameter ( $H = D$ ). The standard Rushton turbine was used. The impeller diameter was  $d = 1/3D$  and the blade thickness to diameter ratio was 0,01. The off-bottom clearance was  $h = d$ . Dimethyl sulfoxide (DMSO) ( $\eta = 0,0023$  Pa·s,  $\rho = 1100$  kg/m<sup>3</sup>) was used as the working fluid.

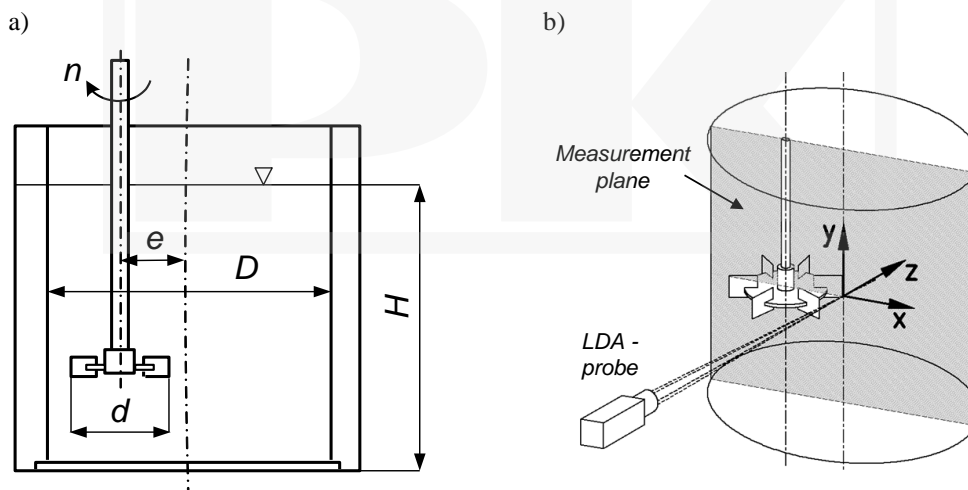

Fig. 1. Stirred vessel with an eccentrically located Rushton turbine;  
a) geometric characteristics of stirred vessel, b) scheme of measuring system

The hydrodynamics investigation involved a visualisation of the liquid flow in the stirred tank and an analysis of the components of the mean flow velocity vectors. Temporary flow velocity measurements were carried out using two-component Laser Doppler Anemometry (LDA) operating in back scatter mode [5]. Argon-Ion laser provided a pair of blue beams with  $\lambda = 488$  nm and a pair of green beams with  $\lambda = 514,5$  nm. The obtained measurement data were processed by a *Dantec Burst Spectrum Analyser*. The working fluid was seeded with silver coated hollow glass spheres with a mean diameter of  $10 \mu\text{m}$  and a density of  $1150 \text{ kg/m}^3$ . Liquid flow visualisation was carried out using a digital camera.

The power consumption ( $P = M \cdot 2\pi n$ ) was determined from torque measurements  $M$  performed on the shaft using torquemeter (*Vibrometer*). At the same time, the impeller rotational speed  $n$  had been measured.

Research was performed for 3 different positions of the impeller shaft from the tank axis: central position ( $e = 0$ ) and two off-axis positions ( $e = 0,25R$ ,  $e = 0,5R$ ), where  $R = D/2$ .

The flow velocity measurements were performed in plane through tank axis and impeller shaft axis (Fig. 1b). The mixing intensity was controlled by impeller rotational speed changes, and ranged from 200 to 600 rpm, corresponding to full turbulent flow in stirred tank and impeller Reynolds number  $Re = (1,44 \div 4,32) \cdot 10^4$ .

### 3. Results and discussion

Fig. 2 shows an example of the impact of the impeller's shaft eccentricity on the liquid flow in an unbaffled stirred tank for a rotational impeller speed of  $n = 250$  rpm. When the impeller is located in the axis of the tank ( $e = 0$ , Fig. 1a), one centrally vortex can be observed. The vortex depth increases with the impeller rotational speed increase. For  $n = 502$  rpm, the vortex departs from the top of the vessel above the impeller. From that moment, some air from above the liquid surface starts to be entrained into the flow. The air was dispersed in the tank by the impeller blades. Displacement of the shaft from tank axis towards the wall causes the formation of the vortex in the field between tank wall and impeller shaft (Fig. 2b). Low rotational speed characterises the presence of a vortex in the upper part of the tank, below the liquid surface. With a rotational speed increase, the vortex reaches more into the bottom of the tank and at a sufficiently rate of rotation, it reaches the impeller blades. The formation of that vortex in the stirred vessel with eccentrically located impeller were also documented in experimental studies [6, 7], as well as in CFD simulations [2]. Authors of the study [6] also observed the creation of the second vortex departing from the impeller blades towards the vessel bottom. In this paper, such results were not observed. The difference can be explained by the fact that in [6], the stirred tank was equipped with an cover, which was located just above the liquid level and prevented air to be entrained into the flow from the above of liquid surface.

The increase of eccentricity changes the location of the forming vortex, which moves toward the tank wall. Equally higher eccentricity corresponds to a higher vortex inclination to the vertical axis of the tank. For  $e = 0,5R$  eccentricity, inclination is  $29^\circ \pm 4^\circ$ . A similar observation has been found in other studies. In paper [6], the upper vortex was inclined by

15°, whereas paper [7] presents an inclination between 16° and 23°. For [7], the root cause of these differences may be explained by a different impeller off-bottom clearance (where  $h = 0,5D$ ), and in case of [6], providing closing cover. No changes of the vortex inclination due to rotational speed were observed.

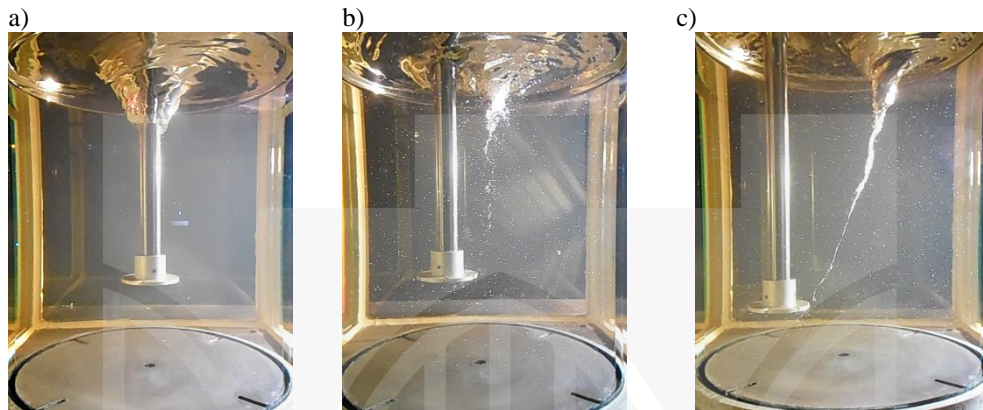

Fig. 2. Flow visualisations with the impeller rotational speed  $n = 250$  rpm for various eccentricity; a)  $e = 0$ , b)  $e = 0,25R$ , c)  $e = 0,5R$

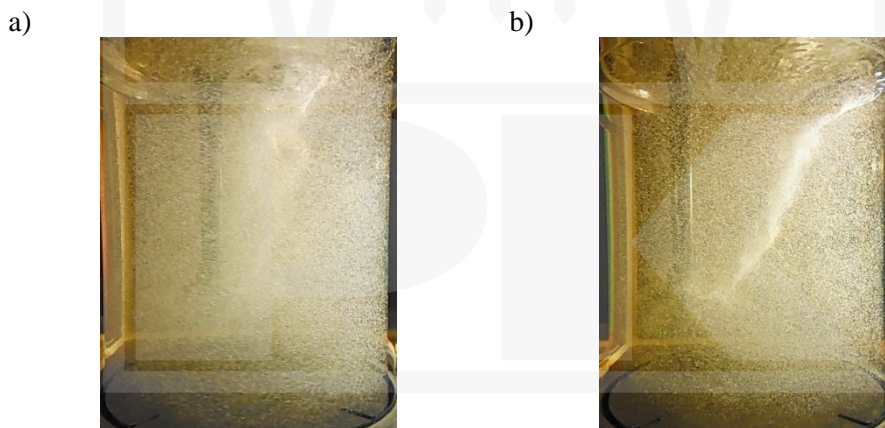

Fig. 3. Air dissipation throughout the volume of the vessel; a)  $e = 0,25R$  and  $n = 354$  rpm, b)  $e = 0,5R$  and  $n = 302$  rpm

The vortex created by the eccentric location of the impeller causes entraining of the gas from the surface into the flow. The intensity of that phenomenon strengthens with an increase of the impeller rotational speed increase and the eccentricity. Fig. 3 shows an example of gas dissipation throughout the volume of the tank for two different  $e$  values. For  $e = 0,25R$  eccentricity, such effect is achieved at rotational speed  $n = 354$  rpm (Fig. 3a), and for  $e = 0,5R$  eccentricity at lower rotational speed  $n = 302$  rpm (Fig. 3b).

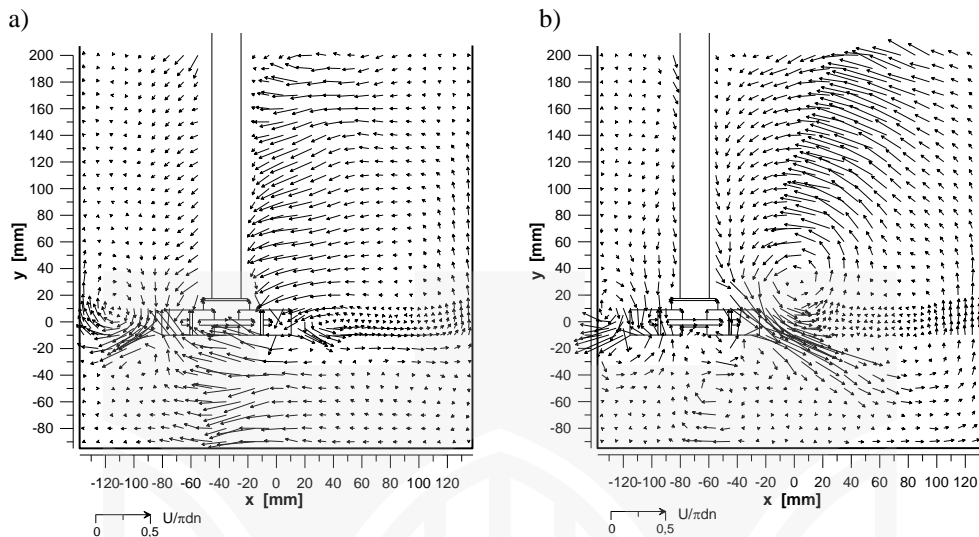

Fig. 4. Vector plot of liquid flow in a stirred vessel with an eccentrically positioned Rushton turbine for various impeller eccentricity: a)  $e = 0,25R$ , b)  $e = 0,5R$

Fig. 4 shows the results of the measurement of the radial and axial components of the mean flow velocity for two different eccentricities:  $e = 0,25R$  (Fig. 4a) and  $e = 0,5R$  (Fig. 4b). Fig. 1b presents the measuring plane. Velocity data determined during mixing with rotational speed  $n = 225$  rpm are presented in dimensionless form, i.e. normalised with respect to the impeller blade tip velocity,  $(U/\pi d \cdot n)$ . Based on the results, it can be stated that for mixing with eccentrically positioned impeller, the flow pattern is not axisymmetric as it is for central position of the impeller [8]. For the eccentricity  $e = 0,25R$  (Fig. 4a), the largest values of the radial component occur in the vortex area from impeller blades towards the top of the vessel. Large radial component values are also observed under Rushton turbine. For the eccentricity  $e = 0,5R$  (Fig. 4b), velocities are much lower, while in the vortex area values of radial velocity components increase. Higher eccentricity also causes significant variation of velocity profiles in the impeller discharge stream. In  $e = 0,5R$  (Fig. 4b) case, the formed vortex affects the flow of the pumped by impeller blades liquid. It results in a significant increase of the radial component of velocity at the side where the distance between the impeller and the tank wall is the largest. In this case, maximum radial velocities are about  $2 \div 2,5$  larger in comparison with  $e = 0,25R$  case. The axial components also increase, which cause the flow stream to be pumped towards the vessel bottom. At the area where the impeller is closest to the vessel wall, the velocity profile changes due to the impeller discharge stream-wall interaction.

The measurement of the power consumption for the stirred vessel without baffles is presented in Fig. 5 as the power characteristic  $Ne = f(Re)$  for different eccentricities  $e/R$  of the impeller shaft. All power characteristics  $Ne = f(Re)$  are found to be independent of the  $Re$  number for the range of the performed experiments. The similar independence was found in [9] for impellers type HE 3 and for propeller stirrer. Marked in Fig 5 by dashed line decrease of power number  $Ne$  for large Reynolds numbers  $Re$ , for eccentric impeller

position, is the result of the increase of aeration of mixing liquid caused by formed in the stirred vessel vortex. The aeration of the liquid increases with the impeller rotational speed increase, which results in mixing liquid density decrease, and therefore, with a decrease of the power number.

The results of the experimental analysis allow to conclude that for the liquid stirring in the unbaffled tank with an eccentrically located impeller, the power number is always larger than for the stirring with centrally located impeller ( $e = 0$ ). Fig. 5 presents also power numbers  $Ne$  for the conventional stirring with four baffles ( $J = 4$ ) and centrally located Rushton turbine ( $e = 0$ ). According to analysis of changes in eccentricity ( $e = 0 \div 0,5R$ ) it can be concluded that power number  $Ne$  for mixing with eccentrically located impeller in the unbaffled stirred tank is always larger than for centric agitation ( $Ne = 0,74$ ) and always lower than for conventional stirred vessel with baffles ( $Ne = 3,75$ ).

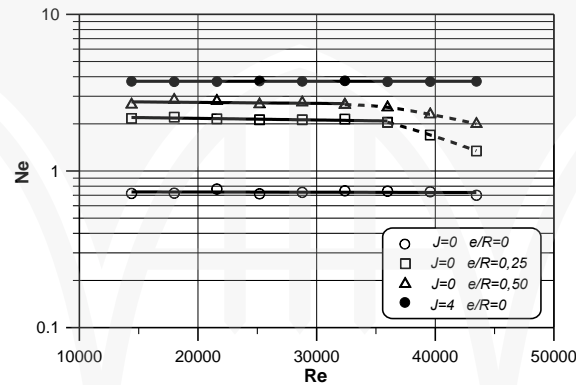

Fig. 5. Power characteristics  $Ne = f(Re)$  for the stirred tank with the Rushton turbine:  $J = 0$  and  $e/R = 0; 0,25; 0,5$  or  $J = 4$  and  $e/R = 0$

The experimentally proven effect of the stirrer eccentricity ratio  $e/R$  on the power number  $Ne$  in the stirred tank without baffles and with the Rushton turbine is depicted in Fig. 6. The obtained results of the measurements were described mathematically and were approximated by the following correlation:

$$Ne = 0,74 \cdot \left[ -6,89 \cdot \left( \frac{e}{R} \right)^2 + 9,04 \cdot \left( \frac{e}{R} \right) + 1 \right] \quad (1)$$

with the maximal relative error  $\pm 5,6\%$ , within the ranges of the  $Re \in \langle 1,44 \cdot 10^4; 4,32 \cdot 10^4 \rangle$  and eccentricity  $e/R \in \langle 0; 0,6 \rangle$ .

Equation (1) describes the evaluated impact of impeller eccentricity  $e/R$  as a quadratic function, which is in agreement with experimental results for Rushton turbine, which were reported in [8, 10]. In [9], the linear relationship  $Ne = f(e/R)$  was estimated; however, it concerned different impeller types (HE 3 and propeller stirrer), which operate as axial pumping impellers. As the conclusion, it can be estimated that the impact of eccentricity on the power number can be presented as a quadratic function for radial pumping impellers, such as the Rushton turbine, and as a linear function for axial pumping impellers.

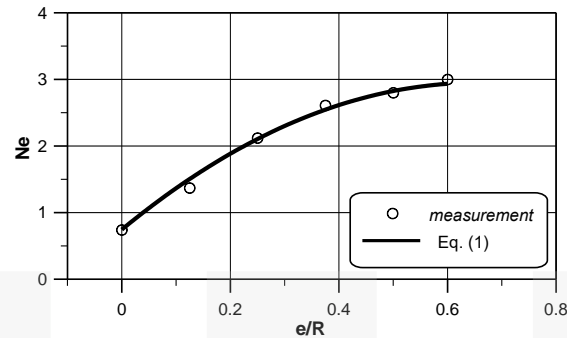

Fig. 6. The dependence  $Ne = f(e/R)$  for the unbaffled stirred tank with the Rushton turbine

#### 4. Conclusions

Displacement of the shaft from tank axis towards the wall causes the formation of the vortex in the field between tank wall and the impeller shaft (Fig. 2b). Low rotational speed characterises the presence of vortex in the upper part of the tank, below the liquid surface. With a rotational speed increase, the vortex reaches closer into the bottom of the tank and at a sufficiently rate of rotation reaches the impeller blades. The increase of eccentricity changes the location of the forming vortex, which moves toward the tank wall. Equally, higher eccentricity corresponds to a higher vortex inclination to the vertical axis of the tank. For  $e = 0,5R$  eccentricity, the inclination is  $29^{\circ} \pm 4^{\circ}$ . No changes of the vortex inclination due to rotational speed were observed.

Based on the results of the measurement of the mean flow velocity, it can be stated that for mixing with eccentrically positioned impeller, the flow pattern is not axisymmetric as it is for central position of the impeller. The largest values of the radial component occur in the vortex area from impeller blades towards the top of the vessel. At the area where the impeller is closest to the vessel wall, the velocity profile changes due to the impeller discharge stream-wall interaction.

According to analysis of changes in eccentricity ( $e = 0 \div 0,5R$ ), it can be concluded that the power number  $Ne$  for mixing with eccentrically located impeller in the unbaffled stirred tank is always larger than for centric agitation ( $Ne = 0,74$ ) and always lower than for conventional stirred vessel with baffles ( $Ne = 3,75$ ).

The experimentally determined effect of the stirrer eccentricity ratio  $e/R$  on the power number  $Ne$  in the stirred tank without baffles and with the Rushton turbine describes equation (1). That correlation estimates that for radial pumping impeller, the impact of eccentricity on power number is a quadratic dependence.

#### Symbols

$d$	impeller diameter, m,
$D$	tank inner diameter, m,

$e$	eccentricity, i.e., distance of the shaft from the vessel axis, m,
$h$	off-bottom clearance of the stirrer, m,
$H$	liquid height in the tank, m,
$M$	torque, N·m,
$n$	impeller rotational speed, $s^{-1}$ ,
$P$	power consumption, W,
$R$	radius of the stirred tank, $R = D/2$ , m,
$U$	mean velocity, $m \cdot s^{-1}$ ,
$Ne$	power number, $Ne = P/(n^3 d^5 \rho)$ , –,
$Re$	impeller Reynolds number, $Re = (n \cdot d^2 \cdot \rho)/\eta$ , –,
$\eta$	dynamic viscosity of the liquid, Pa·s,
$\rho$	liquid density, $kg \cdot m^{-3}$ .

#### References

- [1] Kamiński J., *Mixing of multiphase systems*, WNT, Warszawa 2004 (in Polish).
- [2] Wójtowicz R., Lipin A. A., *The computational-fluid-dynamics study of an unbaffled stirred vessel with eccentrically positioned impeller*, Technical Transactions, series Chemistry, vol. 17(1), 2015, 99-108.
- [3] Rieger F., Dítl P., Novák V., *Vortex depth in mixed unbaffled vessels*, Chemical Engineering Science, vol. 34, 1979, 397-403.
- [4] Ciofalo M., Brucato A., Grisafi F., Torracca N., *Turbulent flow in closed and free-surface unbaffled tanks stirred by radial impellers*, Chemical Engineering Science., vol. 51, 1996, 3557-3573.
- [5] Talaga J., *Measurements of turbulent-flow parameters in a stirred mixer*, Chemical and Process Engineering, vol. 22, 3E, 2001, 1387-1392 (in Polish).
- [6] Galletti C., Brunazzi E., *On the main flow features and instabilities in an unbaffled vessel agitated with an eccentrically located impeller*, Chemical Engineering Science, vol. 63, 2008, 4494-4505.
- [7] Montante G., Bakker A., Paglianti A., Magelli F., *Effect of the shaft eccentricity on the hydrodynamics of unbaffled stirred tanks*, Chemical Engineering Science, vol. 61, 2006, 2807-2814.
- [8] Galletti C., Pintus S. Brunazzi E., *Effect of shaft eccentricity and impeller blade thickness on the vortices features in an unbaffled vessel*, Chemical Engineering Research and Design, vol. 87, 2009, 391-400.
- [9] Karcz J., Cudak M., Szoplik J., *Stirring of a liquid in a stirred tank with an eccentrically located impeller*, Chemical Engineering Science, vol. 60, 2005, 2369-2380.
- [10] Karcz J., Cudak M., *An effect of the type of an eccentrically located impeller on the efficiency of heat transfer process*, In Proceedings of the 12th European Conference on Mixing, 27-30 June 2006, Bologna, Italy, 727-734.