

MARCIN SZCZYGIEL, KRZYSZTOF KLUSZCZYŃSKI*

ROTARY-LINEAR INDUCTION MOTOR BASED ON THE STANDARD 3-PHASE SQUIRREL CAGE INDUCTION MOTOR – CONSTRUCTIONAL AND TECHNOLOGICAL FEATURES

SILNIK INDUKCYJNY OBROTOWO-LINIOWY NA BAZIE STANDARDOWEGO 3-FAZOWEGO SILNIKA KLATKOWEGO – CECHY KONSTRUKCYJNE I TECHNOLOGICZNE

Abstract

Induction motors with some degrees of freedom (more than one) belong to unconventional drives which offer wider possibilities of motion than traditional drives. These motors constitute a small group of electric drives, however, new requirements for mechatronic devices are the cause of growing interest in their steady and regular development. As far as rotary-linear motors are concerned, they can be used in devices dedicated to mixing and drilling ensuring both rotary and linear movements. Because of the complex construction of such motors, their manufacturing process is expensive. In order to reduce these costs, the authors develop and propose the concept of the 3-phase rotary-linear machine built-up on the basis of a standard 3-phase squirrel-cage motor. This approach results in the significant reduction of manufacturing costs through the use of prefabricated parts (e.g. complete stator, stack of stator sheets, motor housing), as well as allowing the partial adoption of technologies used for standard induction motors.

Keywords: squirrel cage induction motor, rotary-linear induction motor, design and technology process

Streszczenie

Silniki indukcyjne o wielu stopniach swobody są napędami niekonwencjonalnymi, które charakteryzują się szerszymi możliwościami ruchu niż tradycyjne napędy realizujące wyłącznie ruch liniowy lub ruch obrotowy. Prognozuje się szerokie zastosowanie silników obrotowo-liniowych jako napędów niekonwencjonalnych w urządzeniach, w których moduł obrotowy odgrywa rolę napędu głównego (roboczego) urządzenia, a moduł liniowy odgrywa rolę aktuatora o ruchu postępowym (napędu pomocniczego pozycjonującego końcówkę roboczą). Taki napęd może być wykorzystany przede wszystkim w urządzeniach do mieszania i mielenia. Ze względu na nietypową budowę silników indukcyjnych obrotowo-liniowych i konieczność zastosowania niestandardowych technologii ich proces produkcji jest kosztowny. W celu ograniczenia kosztów ich wytwarzania zaproponowano koncepcję budowy 3-fazowego silnika indukcyjnego obrotowo-liniowego na bazie elementów składowych 3-fazowego silnika indukcyjnego klatkowego. Postępowanie to opisano w sposób szczegółowy na przykładzie 3-fazowego silnika klatkowego typu ShR90X-8M produkowanego seryjnie. Takie podejście powoduje znaczące obniżenie kosztów wytwarzania silnika o 2 stopniach swobody dzięki wykorzystaniu gotowych elementów 3-fazowego silnika indukcyjnego (w szczególności: kompletnej stojana, pakietu blach, korpusu silnika), a równocześnie umożliwia dostosowanie technologii wytwarzania takiego złożonego przetwornika elektromechanicznego do istniejącego procesu produkcyjnego 3-fazowych silników indukcyjnych.

Słowa kluczowe: silnik indukcyjny klatkowy, silnik obrotowo-liniowy, konstrukcja i technologia wykonania

DOI: 10.4467/2353737XCT.15.059.3859

* Ph.D. Eng. Marcin Szczygieł, Prof. D.Sc. Ph.D. Eng. Krzysztof Kluszczyński, Department of Mechatronics, Faculty of Electrical Engineering, Silesian University of Technology.

1. Introduction

Rotary-linear motors (motors with two degrees of freedom denoted as 2DoF motors) belong to unconventional drives which offer wider possibilities of motion than traditional drives. Especially as they enable the formation of a spiral (helical) rotor trajectory which in conventional drives can be obtained only with the help of additional mechanical components (Fig. 1a)). Of course, they can also work as a rotary or as linear motor which is presented in Fig. 1b) and c) respectively. As regards their application, they can be used for instance in a wide range of devices dedicated to the mixing and drilling process. Such an application in a mixing machine is shown in Fig. 2. From the viewpoint of the manipulator theory, the rotary module works as a main drive unit and a linear module plays the role of a linear actuator responsible for positioning the working tool (stirrer). Another possible application in the drilling machine is presented in Fig. 3.

Different types of rotary-linear motors have different principles of operation: asynchronous [1–4]; synchronous with permanent magnet (PMSM) [3, 4]; ultrasonic motors (USM) [5]; switched reluctance motors (SRM) [6]; brushless DC motors (BLDC) [7].

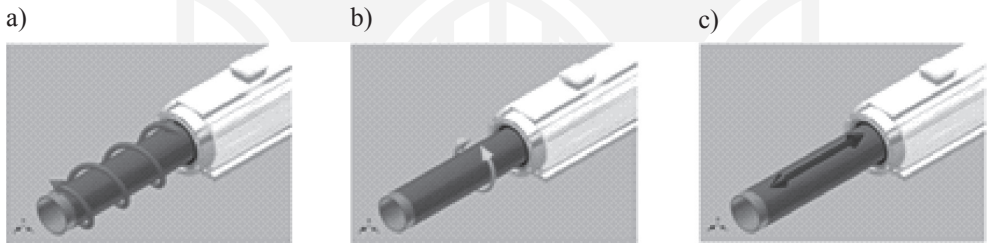

Fig. 1. Trajectories of motion realized by the rotary-linear motor: a) trajectory of the spiral motion (when both linear and rotary modules are supplied), b) trajectory of rotary motion (when only rotary module is supplied), c) trajectory of linear motion (when only linear module is supplied)

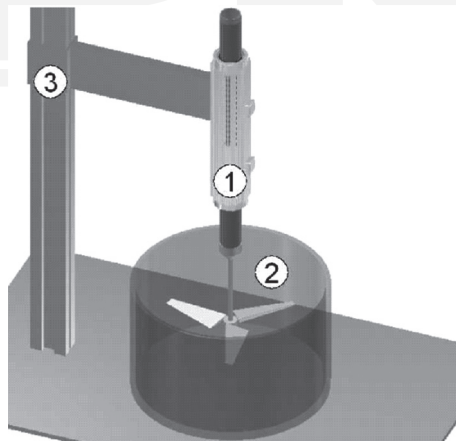

Fig. 2. Exemplary application of rotary-linear motor in mixing machine: 1 – rotary-linear motor, 2 – working tool, 3 – stand

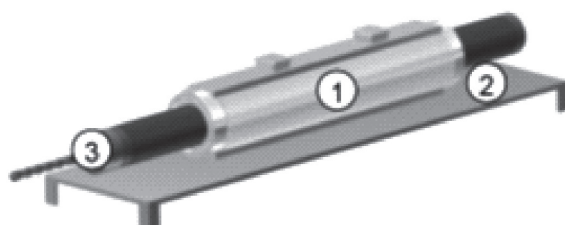

Fig. 3. Exemplary application of rotary-linear motor in drilling machine: 1 – rotary-linear motor, 2 – stand, 3 – working tool

2. Constructional features

The 3-phase rotary-linear motor requires 2 types of windings: 3-phase distributed winding (which generates rotating circular magnetic field and is responsible for rotary motion); 3-phase ring winding (which generates travelling magnetic field and is responsible for linear motion).

As far as their location in the 2DoF motor is concerned, there are 2 main possibilities presented in Figs. 4 and 5, respectively.

Motor with one common stator is compact but more complicated. Both distributed and ring windings are located in the common stator and have a common magnetic circuit. The horizontal conductors of a distributed winding and the vertical conductors of a ring winding are mutually perpendicular. This means that the magnetic field density vector in the air-gap of the machine has two perpendicular components relating to the circular and travelling magnetic fields, respectively. Such a 2-dimensional magnetic field requires special construction of a rotor (bar-crossed rotor) [6]. Of course, it is possible to replace this rotor by a solid or tubular rotor which can also interact with both components of the magnetic field [5].

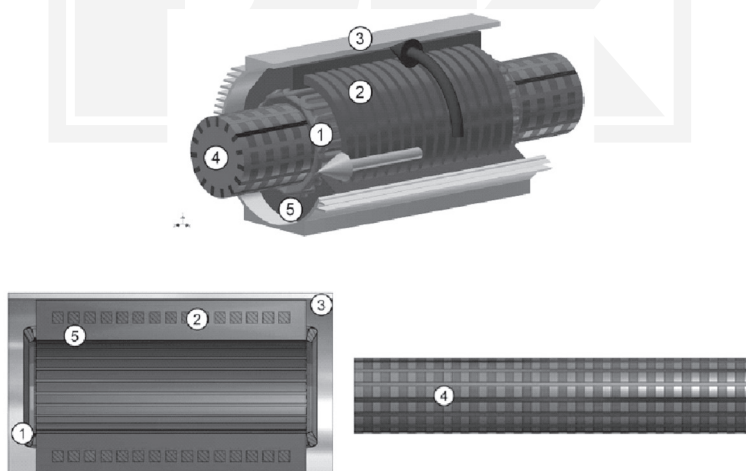

Fig. 4. 2DoF induction motor with one common stator: a) general view, b) cross-section of stator, c) bar-crossed rotor: 1 – winding which generates the rotating circular magnetic field, 2 – ring winding which generates the travelling magnetic field, 3 – housing, 4 – rotor, 5 – common iron core

The motor with two stators has a simpler construction but its total length is usually greater. The two autonomous stators are equipped in two separate windings which can act with a bar-crossed, solid or tubular rotor. The winding located in the first stator (which is called the linear module LM) is responsible for linear motion and the winding located in the secondary stator (called the rotary module RM) is responsible for rotary motion. It is assumed that the both modules can work autonomously.

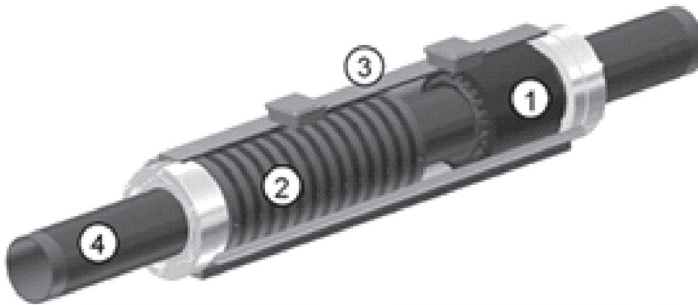

Fig. 5. 2DoF induction motor with two stators: 1 – stator which generates the rotating circular magnetic field, 2 – stator which generates the travelling magnetic field, 3 – housing, 4 – rotor

3. General description of the prototype built on the basis of the induction motor ShR90X-8M

Because of the unconventional construction of the rotary-linear induction motors, non-standard technologies have to be usually employed and, as a consequence, their production process is expensive in comparison with the normal manufacturing process. In order to reduce manufacturing costs, the authors develop and propose the concept of the 3-phase rotary-linear induction motor based on the components of a factory-manufactured 3-phase squirrel cage induction motor.

This approach results in a significant reduction in manufacturing costs through the use of ready-made components (e.g. a complete stator, the motor housing), and at the same time, allows the incorporation of existing technology used in the production process of 3-phase motors.

The main assumed goal during the designing of the 3-phase induction rotary-linear motor was to use as great a number of ready-made components as possible in the 3-phase factory-manufactured squirrel cage induction motor. This assumption results in a relatively cheap and simple production process.

The induction rotary-linear motor elaborated in the Department of Mechatronics at the Silesian University of Technology was made of components normally used for manufacturing the ShR 90X-8M motor. The squirrel-cage motor used as the basis for the new construction has the following specifications: $P_N = 750$ W; $U_N = 400$ V; $I_N = 2.7$ A; $n_N = 670$ rpm; $2p = 4$; $Q_s = 24$.

3.1. The design of rotary module RM

As has seen in Fig.6, the stator of the module RM is the same as the stator of the 3-phase squirrel-cage motor (including both the magnetic core and the 3-phase distributed winding).

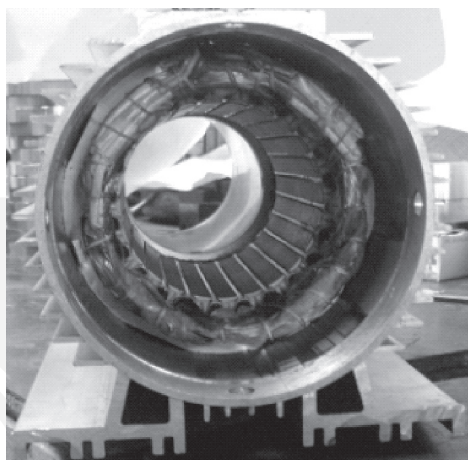

Fig. 6. Module RM – stator ShR 90X-8M after mounting in the housing of the rotary-linear motor

The stator core consist of 240 sheets with a thickness of 0.5 mm (including insulation) made of isotropic electrical tape V600-50A DIN 46400. The stator winding of module RM is a single-layer winding with number of turns $N_s^R = 428$.

3.2. The design of the linear module LM

In order to construct the linear module LM, it is necessary to have sheets of the standard motor which are non-slotted (Fig. 7a) and b)) – this means that during their manufacturing in a factory it is necessary to omit the technological process of slot cutting (Fig. 7a)). The stator of the LM module consists of 13 stacks of the above mentioned non-slotted iron sheets (Fig. 7b)) forming 13 ‘laminated ferromagnetic rings’ (one of which is presented in Fig. 7a)) having an external diameter equal to the external diameter of the basic stator (Fig. 6). These 13 ‘laminated ferromagnetic rings’ (Fig. 7a)) are separated by 12 ‘solid ferromagnetic rings’ (Fig. 8a)) whose external diameter is the same as the diameter of the basic stator. Because of the difference in the internal diameters of the ‘laminated rings’ and the ‘solid rings’ (Fig. 8a)), 12 slots are formed in which the ring winding (Fig. 8b)) can be put (Fig. 8c)). From the electromagnetic point of view, the ‘laminated ferromagnetic rings’ play the role of big teeth and the ‘solid ferromagnetic rings’ play the role of yokes.

The general view of linear module LM consisting of 13 ‘laminated rings’, 12 ‘solid rings’ and 12 coil rings is presented in Fig. 9a) (computer visualization). The photo of the finished stator of the linear module LM (being part of the constructed prototype) is presented in Fig. 9b).

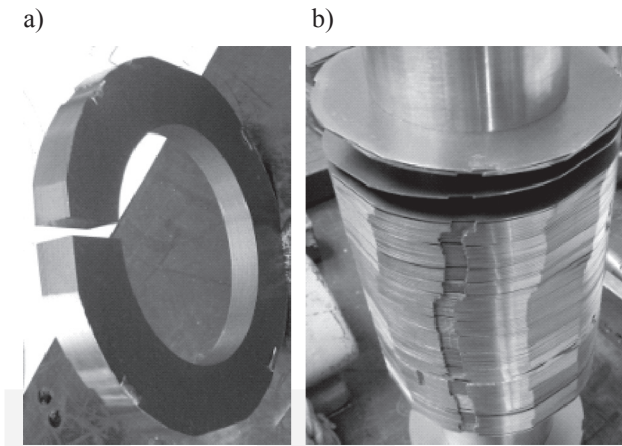

Fig. 7. Iron sheet used in construction of linear module LM of 2DoF motor and non-slotted 'laminated ring' which formed teeth of module LM: a) 'laminated ring', b) non-slotted stator iron sheet

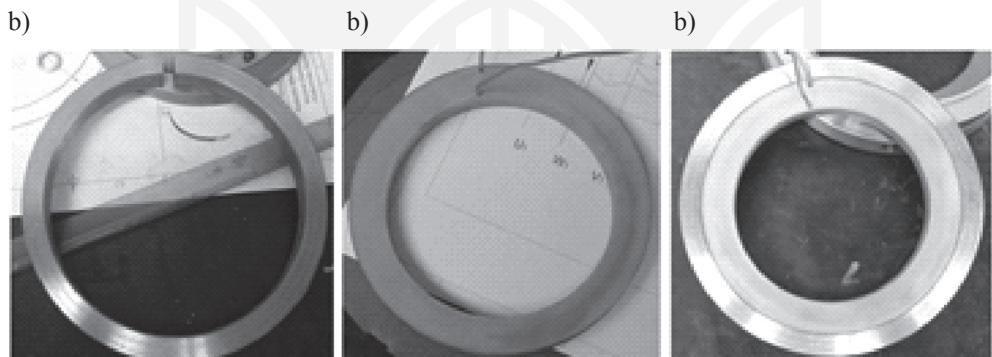

Fig. 8. Constructional components of LM module: a) 'solid ferromagnetic ring', b) ring winding, c) ring winding placed in 'solid ferromagnetic ring'

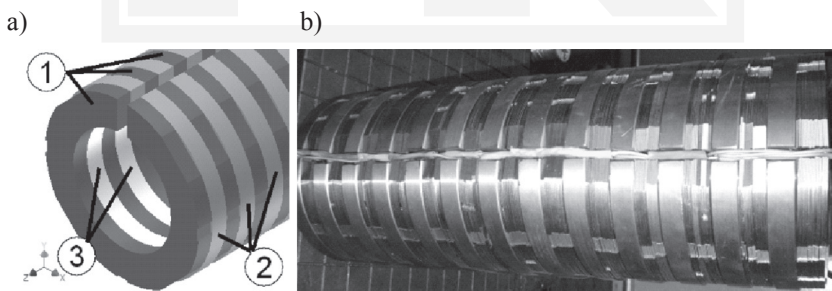

Fig. 9. Module LM: a) perspective computer view, b) constructed prototype

3.3. Design of the rotor with a solid conductive layer

The magnetic circuit of rotor in the rotary-linear induction motor is a steel tube made of structural steel R65, which has been coated with a copper layer having a thickness $\Delta_{Cu} = 0.5$ mm, coated in an electrolytic method (Fig. 10).

In the known solutions of rotary-linear induction motors designers usually use solid rotors. Solid rotor is much heavier and has a large moment of inertia. Because of that oscillations of the electromagnetic torque in a motor are not observed during its start. It should be noted, however, that the use of massive rotor significantly increases the mechanical time constant of the motor. It also requires the design of the bearing with much greater strength, capable of delivering large forces and moments acting in the supporting point of the rotor.

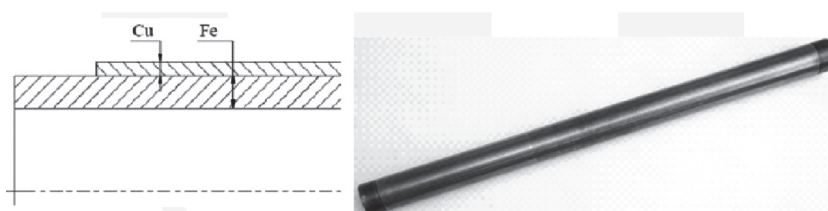

Fig. 10. Tubular rotor of 2DoF induction motor (cross-section and real view)

3.4. Construction of motor housing

The body of an rotary-linear induction motor is made of profiled aluminium tube, normally used in the manufacture of motors ShR-8M 90X IMB version (Fig. 11).

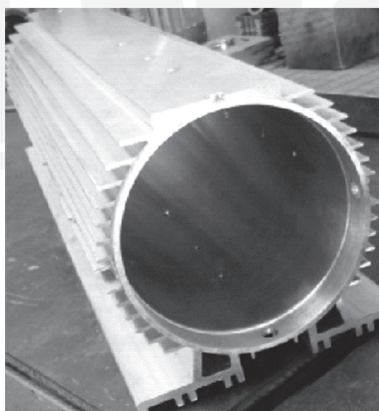

Fig. 11. The housing of an rotary-linear induction motor

The considerable length of the housing is the reason for applying a tight fitting in the RM module and in the LM module. The value of the fitting for the RM module is equal to 135H7/n6 and value of fitting for LM module equals $\text{Ø}135\text{H7/p6}$. Additionally, to make sure that the

construction is sufficiently stiff, numerous screws are used. The number of screws joining the housing with the RM module is equal to 8 and in the presented prototype, is the same as the number of screws joining the housing with the LM module.

3.5. Construction of rotary-linear bearing system

One of possible solutions for a bearing system (Figs. 12 and 13) is to use a truck. The truck mounted on the slide enables a rotor to move forward, to move backward, as well as to rotate around its axis. Another possibility for a bearing system is to put the rotor directly on an internal surface of bearings. Such a solution requires special material extremely resistant to abrasion, for instance Teflon. Because the external diameter of the designed motor was out of the standardised diameters of the factory-manufactured Teflon bearings, it was necessary to elaborate a bespoke solution for the bearing system consisting of two rolling bearings and a plain bearing made of polymer PA T-27MHS. This concept is presented in Fig. 12.

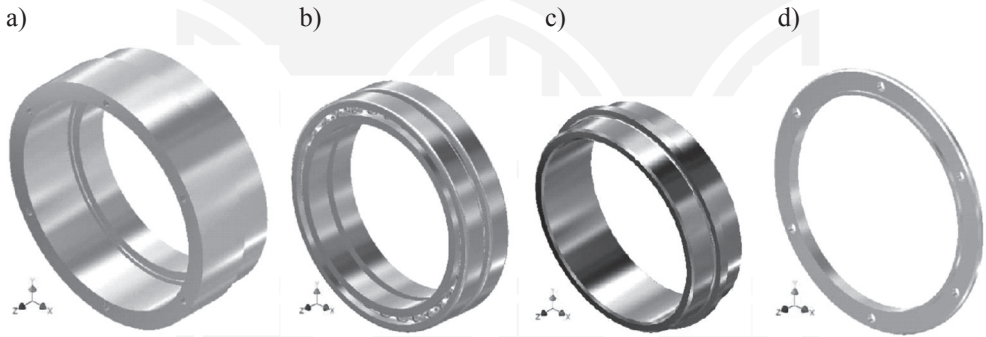

Fig. 12. The rotary-linear bearing system: a) front cover, b) two ball bearings (with parameters: static nominal load $C_0 = 22.8$ kN; dynamic nominal load $C = 19.9$ kN; fatigue load limit $P_U = 0.93$ kN; speed limit $n_{\max} = 3000$ rpm), c) plain bearing made of polymer PA T-27MHS, d) locking ring

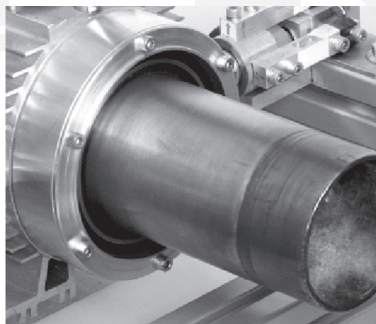

Fig. 13. The photo of mounted rotary-linear bearing system

4. Design methodology

The design methodology based on an analytical circuit model and on a field model implemented in the FEMM program. As regards the former method, the equivalent circuit of an induction motor with a solid rotor [8–10] is presented in Fig. 14.

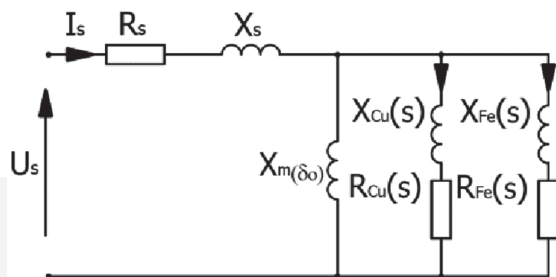

Fig. 14. The equivalent circuit of an induction motor with solid rotor [8–10]

The impedance of the rotor with the solid conductive layer (referred to the stator) is given by the following formula:

$$Z_r' = \frac{\frac{j \omega \mu_{Fe} l_{Fe}}{\kappa_{Fe} \tau_p \tanh(\kappa_{Fe} \Delta_{Fe})} \frac{j \omega \mu_{Cu} l_{Fe}}{\kappa_{Cu} \tau_p \tanh(\kappa_{Cu} \Delta_{Cu})}}{\frac{j \omega \mu_{Fe} l_{Fe}}{\kappa_{Fe} \tau_p \tanh(\kappa_{Fe} \Delta_{Fe})} + \frac{j \omega \mu_{Cu} l_{Fe}}{\kappa_{Cu} \tau_p \tanh(\kappa_{Cu} \Delta_{Cu})}} \frac{m_s}{m_r} \left(\frac{N_s k_{ws}}{N_r k_{wr}} \right)^2 \quad (1)$$

where:

- κ_{Fe}, κ_{Cu} – attenuation coefficients (for iron and copper),
- Δ_{Fe}, Δ_{Cu} – thickness of layers (for iron and copper),
- μ_{Fe}, μ_{Cu} – the relative permeability (for iron and copper),
- l_{Fe} – length of iron core,
- τ_p – pole pitch,
- m_s – number of phase of stator,
- m_r – number of phase of solid rotor equal the number of poles $2p$,
- N_s – number of turns of stator,
- N_r – number of turns of rotor (for solid rotor $N_r = 0.5$),
- k_{ws}, k_{wr} – winding coefficients,
- ω – pulsation.

As far as the latter method is concerned, the special procedure in Lua language for the FEMM program (Finite Elements Method for Magnetics) is employed. It enables determining the spatial distribution of the magnetic field in the machine and, in consequence, allows calculating electromechanical curves – torque vs. slip $T_e = f(s)$ and force vs. slip $F_e = f(s)$, as well as phase current vs. slip $I_s = f(s)$.

Exemplary spatial distributions of the magnetic field in the RM module at standstill (the blocked rotor) and at no load state, are presented in Fig. 15. The highest saturation points occur on the surface of the tubular rotor and are equal to about $B_{\max} = 2$ T for both of the considered states.

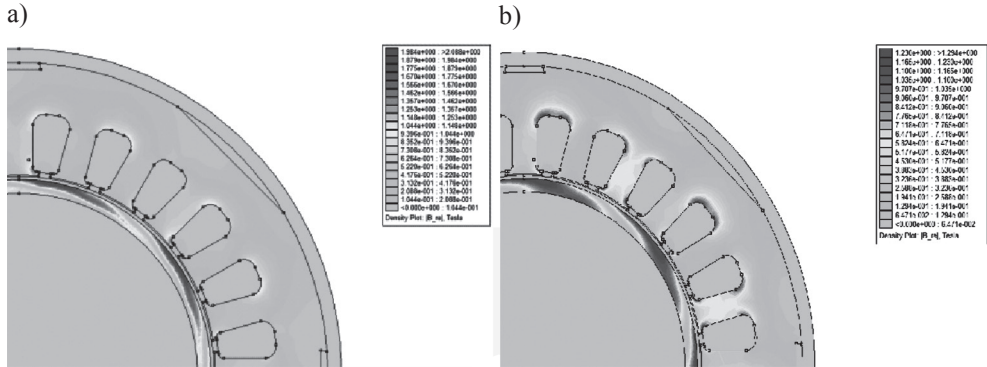

Fig. 15. The exemplary distribution of magnetic field in the module RM: a) blocked rotor state, b) no load state

Exemplary spatial distributions of magnetic field in the LM module at standstill and at no load state, are depicted in Fig. 16. The highest saturation points occur on the surface of the tubular rotor and equal to about $B_{\max} = 2$ T for the case of the blocked rotor and to about $B_{\max} = 1.6$ T for the case of no load state, respectively.

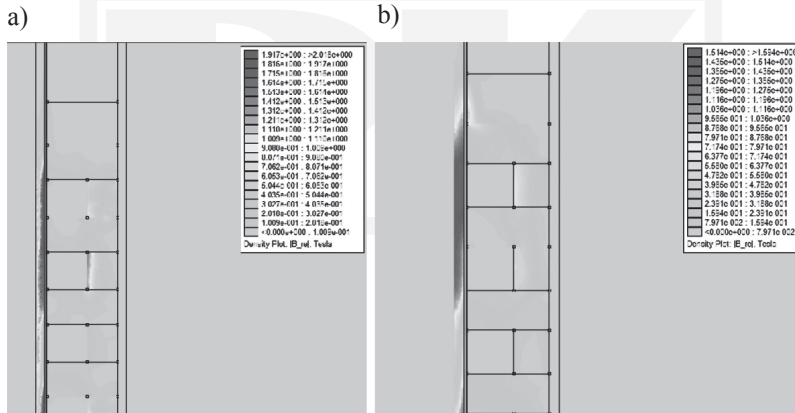

Fig. 16. The exemplary distribution of magnetic field in the module LM: a) blocked rotor state, b) no load state

Based on the above field calculations, the curves – electromagnetic torque vs. slip $T_e = f(s)$ and stator current vs. slip $I_s^R = f(s)$ for the module RM are determined (Fig. 17). Analogously, the curves – electromagnetic force vs. slip $F_e = f(s)$ and stator current vs. slip $I_s^L = f(s)$ for the module LM are calculated and presented in Fig. 18.

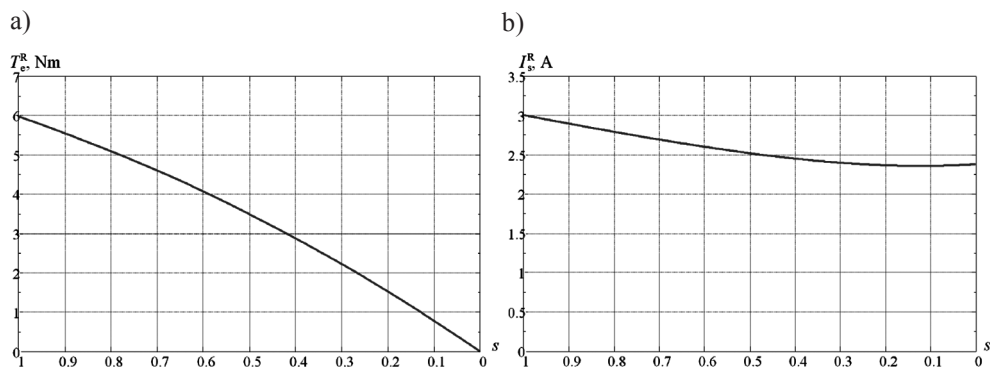

Fig. 17. The electromagnetic torque vs. slip curve $T_e = f(s)$ and stator current vs. slip curve $I_s^R = f(s)$ of module RM

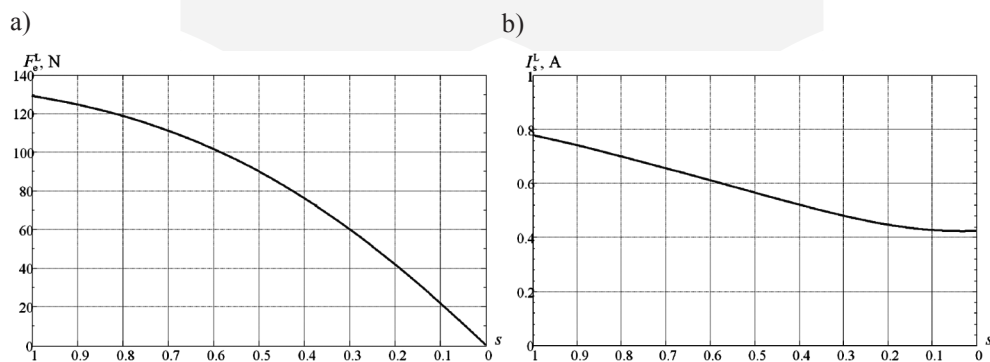

Fig. 18. The electromagnetic force vs. slip curve $F_e = f(s)$ and stator current vs. slip curve $I_s^L = f(s)$ of module LM

Both methods – the analytical method based on the equivalent circuit of an induction motor with a solid rotor and the field method based on the procedure in Lua language for FEMM program are employed in the designing process of the constructed prototype.

5. Conclusions

The idea of converting the conventional (factory-manufactured) squirrel-cage induction motor in the non-conventional rotary-linear induction motor is very useful. It allows the producers of the electrical machines to widen, in an easy way and without considerable investment, their offer by putting on the market a new non-conventional rotary-linear actuator. On the other hand, this concept can be effectively developed in an academic laboratory by advanced students on their own. The goal, which can be easily achieved in the university, is a new educational laboratory stand combined with students' training and satisfaction.

References

- [1] Szczygieł M., *Modelowanie silnika indukcyjnego o dwóch stopniach swobody ruchu oraz badanie jego właściwości eksploatacyjnych przy wykorzystaniu magnetoreologicznego hamulca obrotowo-liniowego*, Ph.D. Thesis, Silesian University of Technology, Gliwice 2011.
- [2] Szczygieł M., Trawiński T., Pilch Z., Kluszczyński K., *Modeling the bench for electro-mechanical devices with two degrees of freedom*, Przegląd Elektrotechniczny (Electrical Review), 2009, No. 12.
- [3] Kamiński G., *Motors with rolling rotors*, WPW, Warszawa 2003.
- [4] Mendrela E., Fleszar J., Gierczak E., *Modeling of induction motors with one and two degrees of mechanical freedom*, Kluwer Academic Publishers, Boston 2003.
- [5] Mashimo T., Toyama S., *Micro Rotary-Linear Ultrasonic Motor for Endovascular Diagnosis and Surgery*, IEEE International Conference on Robotics and Automation, Pasadena, CA, USA 2008.
- [6] Pan J.F., Cheung N.C., Guang-zhong Cao, *Investigation of a rotary-linear switched reluctance motor*, XIX International Conference on Electrical Machines (ICEM), 2010.
- [7] Bolognesi P., Taponecco L., *A Novel 2-Freedom-Degrees Brushless Motor*, 0-7803-7369-3/02 2002 IEEE.
- [8] Dabrowski M., Gieras J.F., *Induction Motors with Solid-Rotor*, PWN, Warszawa 1977.
- [9] Gieras J.F., Eastham A.R., Dawson G.E., *Performance calculation for single-sided linear induction motors with a solid steel reaction plate under constant current excitation*, IEE Proceedings Electric Power Applications, 1985, Vol. 132.
- [10] Gieras J.F., Saari J., *Performance calculation for a High-Speed Solid-Rotor Induction Motor*, IECON, Phoenix, Arizona, USA 2010.

