

RENATA CICHA-SZOT, SŁAWOMIR FALKOWICZ*

PROCEDURE OF PREPARATION BRITTLE GEL SAMPLE FOR RHEOLOGICAL MEASUREMENT IN PLATE-PLATE SYSTEM

PROCEDURA PRZYGOTOWANIA KRUCHYCH PRÓBEK ŻELI DO POMIARÓW OSCYLACYJNYCH ZA POMOCĄ UKŁADU PŁYTKA-PŁYTKA

Abstract

New way of preparation brittle gel samples for determining gel strength during oscillatory measurements in plate-plate system was presented in this paper. Presented procedure of sample preparation greatly decrease a cost of selection proper additive for improving gel strength and enable to obtain more reliable evaluation of gel's mechanical properties. Moreover, by external preparation of corrosive samples (e.g. silicate gelling systems) gel's aging time can be prolonged without the impact on sensor's lifetime

Keywords: determining of the gel strength, silicate gels, sample preparation, brittle gels

Streszczenie

W artykule przedstawiono nowy sposób przygotowania próbek kruchych żeli do pomiarów oscylacyjnych w układzie płytka-płytki. Przedstawiona procedura przygotowania próbki w znacznym stopniu ogranicza koszty doboru modyfikatorów żeli oraz pozwala na bardziej precyzyjne określenie właściwości mechanicznych żelu. Ponadto przygotowanie próbki (np. silnie alkalicznych lub kwasowych cieczy na bazie krzemianów) poza elementem pomiarowym reometru pozwala na wydłużenie czasu starzenia żelu bez wpływu na żywotność elementu pomiarowego.

Słowa kluczowe: określenie wytrzymałości żelu, żele krzemianowe, przygotowanie próbki, żele kruche

* Mgr inż. Renata Cicha-Szot, dr inż. Sławomir Falkowicz, Instytut Nafty i Gazu w Krakowie, Zakład Inżynierii Naftowej.

1. Introduction

Determining the consistency of gelling system is of great practical interest [1]. Among the techniques, which characterize polymers and polymer like solutions, rheology is considered the most complete [2, 3]. Presently three methods are accepted for rheological study of crosslinking polymers. In the first method the polymer in a liquid state is exposed to shear flow. The measured viscosity increases with increasing extent of reactions until the material break or until stress reaches the limits of instrument [4, 5–7]. In the second method sample is subjected to small amplitude oscillatory shear mode. The measurement has to be done within the linear viscoelastic region (LVR). Conducting rheological tests in this manner avoid to overstrain the sample which may cause destruction of elastic structure. The measured components of the complex modulus (storage moduli and loss moduli) during the crosslinking process show viscoelastic behavior of the gelling system [2, 5, 6]. The third method, based on small vibrations of fork rheometer, is used for better understanding and complete characterization of sol-gel transition. This method provide additional information on complexity of coagulation and gelation process, which is not monotone and single direction. In some polymer systems after initiation of gelation, a transient process starts and the viscosity of system is fluctuating between wide limits (Fig. 1) [8].

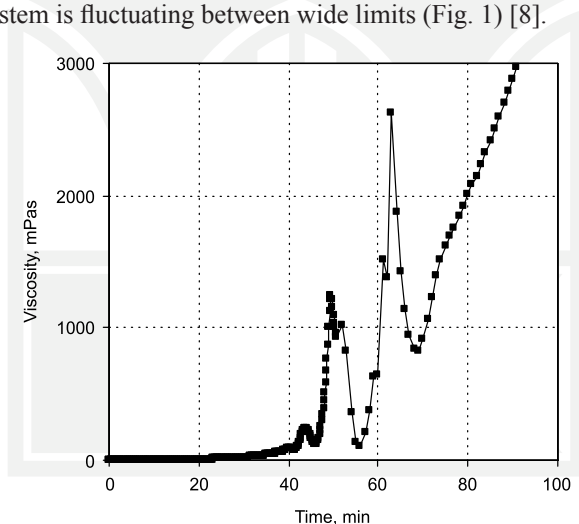

Fig. 1. Transient, induction period of gelation in modified silicate systems [8]

Rys. 1. Krótkotrwałe zmiany lepkości podczas żelowania modyfikowanego krzemianu sodu [8]

Viscoelastic behavior of the gel sample is responsible of the gel consistency at different temperature, time and pH [2]. That is why for complete characterization of the gelling system second method is the most recommended. The most used sensors for dynamic evaluation of the gelling system is plate-plate geometry. Using that sensor the gelling system has been characterized by imposing defined oscillatory strain at a fixed stress rate. Therefore in phase (elastic component – storage modulus G') and out phase (viscous component – loss modulus G'') response of the gel is measured. This two moduli are the components of complex modulus

G^* which represents the total resistance of the substance against the maximum applied strain what indicate gel strength [2, 9].

2. Silicate gelling system

Silicate gelling systems, which are the current state-of-the-art method for porous rock permeability modification in petroleum industry, display a pH-dependent transition between a soluble form and gel form. A gel network is formed after exceed critical pH, and beyond gel point it firmness continues to increase with increasing cross linking density. One of the main problem during determination viscoelastic properties of silicate gelling system is brief or very slow sol-gel transition time and specific properties of silicate gel such as brittleness, shrinking/syneresis [10]. Moreover, modification or destruction of the building tridimensional structures in gel network, that might occur at shear rate and oscillation has to be taken into consideration. Above mentioned disadvantages impede measurement accuracy and make impossible to determine gel strength of such a challenging samples.

In regard to cost effectiveness and measurement accuracy, existing procedures are not proper for determining gel strength of the biocatalysed gelling systems or to match the additives to improve its properties.

3. New procedure of sample preparation

To avoid all mentioned above disadvantages and decrease a cost of sample preparation in Polish Oil and Gas Institute (POGI) new stand and procedure of preparation modified silicate based gel samples was invented. Invention was registered by Polish Patent Office No 119464.

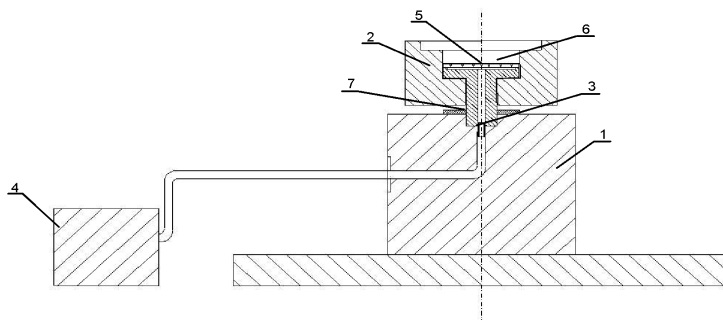

Fig. 1. Lab stand to prepare samples to evaluation viscoelastic properties of brittle gels: 1 – support stand, 2 – chamber, 3 – butt-coupling, 4 – vacuum pump, 5 – perforation, 6 – membrane, 7 – piston

Rys. 1. Przyrząd do wykonywania próbek do pomiaru wiskoelastycznych właściwości kruchych żeli: 1 – statyw, 2 – naczynie, 3 – króciec, 4 – pompa próżniowa, 5 – perforacja, 6 – membrana, 7 – tłok

To perform oscillatory measurement using plate-plate sensor there is a need to prepare cylindrical sample in dimension of plate sensor (e.g. 50mm) and precisely place on the bottom plate of rheometer. Invented lab stand to prepare such a sample consist of cylindrical chamber (2), support stand (1) and vacuum pump (4) (Fig. 1.).

Plastic membrane at the bottom of the sample chamber is placed (6) to separate the gel and the chamber walls and prevent gel adhesion to the bottom of the chamber. Membrane is kept hermetically at the bottom of the chamber by supply through perforation (5) negative pressure which is produced by the vacuum pump [11].

Using graduated pipette relevant amount of the previously prepared silicate sol is placed in the chamber. After the sol-gel transition negative pressure is disconnected and gel can be placed at the sensor's bottom plate. Sample is placed precisely at the center of the bottom plate by the piston and the measurement can be carried out

4. Conclusions

To evaluate with required accuracy rheological properties of brittle silicate gels new stand and procedure of sample preparing was invented. Using special chamber sample can be prepared at required atmosphere (inert, CO₂, oxygen) what enable of gel networking via homogeneous and heterogeneous catalysis as well as biocatalysis.

This technique allows to test substantial number of silicate gel modifiers and strongly decrease number of time consuming tests on samples of porous rocks. Moreover, by external preparation of corrosive samples (e.g. silicate gelling systems) we can prolong the gels ageing time without the impact on sensor's lifetime.

References

- [1] Michon C., Cuvelier G., Launay B., *Concentration Dependence of the Critical Viscoelastic Properties Of Gelatin at Gel Point*, Rheological Acta, 32, 94, 1993.
- [2] Kakadjian S., Raucio O., Mejias F., *Dynamic Rheology as a Method for Quantify Gel Strength of Water Shutoff Systems*, SPE 50751, 1999.
- [3] Winter H., Chambon F., *Analysis of linear viscoelasticity of a crosslinking polymer at the Gel Point*, Journal of Rheology, 30 (2), 367, 1986.
- [4] Castro J., Macosko C., Perry S., *Urethane Polymerization with Phase Separation*, Polym. Com., 25, 82, 1984.
- [5] Farris R., Lee C., *Rheological Behaviour of a Commercial TGDDM-DDS Based Epoxy Matrix During the Isothermal Cure*, Polymers Engineering and Science, 23, 586, 1983.
- [6] Chambon G., Winter H., *Stopping Of Crosslinking Reaction in a PDMS Polymer at Gel Point*, Polymers Bull., 13, 499, 1985.
- [7] Lukah G., Sun S.T., *Gelled Aqueous composition*, Patent USA 4604217, 1986.
- [8] Lakatos I., Medic B., Jovicic D., Basic I., Lakatos-Szabo J., *Prevention of Vertical Gas Flow in a Collapsed Well Using Silicate/Polymer/Urea Method*, SPE 121045, 2009.
- [9] Schramm G., *A Practical Approach to Rheology and Rheometry*, HAAKE, 1997.
- [10] Falkowicz S., Cicha-Szot R., Dubiel S., Bailey S., *Biocatalized silicate gels in oil and geothermal industry*, Gospodarka Surowcami Mineralnymi, Tom 25, Zeszyt 4, 2009.
- [11] Falkowicz S., Cicha-Szot R., *Przyrząd do przygotowania próbek żeli*, WU. No 119464, 15, 11, 2010.